

Surge protection for Ethernet and Fast Ethernet networks

To date, Ethernet is the most commonly used technology for local area networks. The name "Ether" refers to the first radio networks. Introduced in the 1980s, the 10 MBit Ethernet used coaxial cables. Later Fast Ethernet with 100 MBit/s and Gigabit Ethernet with 1000 MBit/s and 10 GBit/s were introduced. All Ethernet versions are based on the same principles. From the 1990s on, Ethernet became the most widely used LAN (Local Area Network) technology and replaced other LAN standards such as Token Ring and ARCNET. Ethernet consists of different types of 50 Ω coaxial cables or twisted pair cables, glass fibre cables or other media. At present, Ethernet typically has a data rate of 100 MBit/s, however, data rates of 1000 MBit/s are on the rise.

Surges cause malfunction and destruction and thus failure of computer systems. This can significantly affect operations, resulting in long standstill of the installations and systems. Therefore, surge protection concepts are required in addition to the protection of the power supply system and regular data backups to ensure reliable operation of computer systems.

Causes of damage

Failure of computer systems is typically caused by:

- ➔ Remote lightning strikes causing conducted transients in power supply, data or telecommunication lines,
- ➔ Nearby lightning strikes causing electromagnetic fields that inject transients into power supply, data or telecommunication lines,
- ➔ Direct lightning strikes causing impermissibly high potential differences and partial lightning currents in the building installations.

Structured cabling as uniform connection medium

Structured cabling is a uniform connection medium for different services such as analogue telephones, ISDN or different network technologies. Consequently, existing installations can be easily adapted to new tasks without exchanging the cables or connection parts. A structured cabling system provides application-independent and universal cables which are not tailored to a specific network topology, manufacturer or product. The type of cables and the topology ensure that all current and future protocols can be used.

A universal cabling system consists of three different hierarchical levels:

1. The **campus backbone cabling** connects the campus distributor of a building complex to the building distributors of the individual buildings. In case of data networks, 50 μm / 125 μm multimode optical fibre cables (in case of distances > 2 km monomode optical fibre cables) with a maximum length of about 1500 m are mainly used.

2. The **building backbone cabling** connects the building distributors to the floor distributors. Also in this case, 50 μm optical fibre cables and balanced 100 ohm cables with a length of 500 m are mainly used.
3. The **horizontal cabling** (floor distributor) includes all cables of the work stations of a floor and should not exceed 90 m. Copper cables or in some cases 62.5 μm optical fibre cables are typically used to connect the floor distributor to the telecommunication outlet.

The interfaces between these areas form passive distribution panels. Such distribution panels link the campus backbone, building backbone and horizontal cabling of universal cabling systems. They allow to easily start communication services on a work station by simply patching patch cables. Distribution panels for optical fibre cables (campus backbone and building backbone) and twisted pair cables (horizontal cabling) differ according to the number of ports. For example, 24 ports are commonly used for structured cabling systems and 25 ports for telecommunication installations. Cables are typically installed in 19" data cabinets or racks.

Star topologies are used for generic cabling systems. All currently available protocols can be operated by means of star topologies irrespective of whether they form a logical ring or bus system.

Structured cabling systems connect all terminal devices. They allow communication between telephones, networks, safety systems, building automation systems, LAN and WLAN interconnection as well as access to the intranet and internet. Generic cabling systems ensure flexible use of terminal devices. It is assumed that all information such as data, voice, television, automation and control of machines and installations will be transmitted via Ethernet over the next years and Ethernet will thus become a universal transmission concept. Therefore, electromagnetic compatibility (EMC) must be ensured.

EMC concept

Electromagnetic compatibility is defined as the capability of a device – especially of an installation or a system – to properly operate in its electromagnetic environment without causing electromagnetic interference itself which would be unacceptable for devices, installations or systems in this environment.

To ensure continuous and trouble-free operation of data networks, it is therefore imperative to consider EMC at an early stage. This does not only affect the data cables of the network, but also the entire electrotechnical infrastructure of the buildings and building complexes where the entire network should be installed. Consequently, it is important to consider the electromagnetic environmental conditions:

- ➔ Are there potential sources of electromagnetic interference such as radio-relay systems, mobile phone base stations, assembly lines or elevators?
- ➔ What about the quality of the electrical energy (e.g. harmonics, flickers, voltage drops, excess voltages, transients)?
- ➔ What about the risk of a lightning strike (e.g. frequency)?
- ➔ Is there possible emission?

To ensure the performance of data networks even in case of the increased requirements to be expected in the future, special attention has to be given to the electromagnetic compatibility of the installation. Therefore, the design of a data network should include an earthing and equipotential bonding concept which provides information on:

- ➔ Cable duct and cable routing
- ➔ Cable structure
- ➔ Active components
- ➔ Lightning protection
- ➔ Shielding of signal lines
- ➔ Equipotential bonding
- ➔ Surge protection

The most important measures to ensure EMC and thus undisturbed data transmission are:

- ➔ Spatial separation of known sources of electromagnetic interference (e.g. transformer stations, elevator drives) of information technology components
- ➔ Use of closed and earthed metal ducts in case of interference caused by strong radio transmitters and, if required, connection of the terminal devices via optical fibre cables only
- ➔ Use of separate circuits for terminal devices and use of noise filters and uninterrupted power supply systems, if required
- ➔ No parallel installation of power and data lines of terminal devices with power lines of powerful loads (due to the risk of high switching overvoltages when switching on / off the loads) and known sources of interference (e.g. thyristor controllers)
- ➔ Use of shielded data cables which must be earthed on both ends (**Figure 9.11.1**). Patch and connecting cables must be integrated in the shielding concept.
- ➔ Integration of the reinforcement (intermeshing) in the equipotential bonding system (**Figure 9.11.2**) for metal enclosures and shields (e.g. cable trays, cable ducts)

- ➔ Shielded data cables and power lines should use the same riser duct in the building backbone area. Separate riser ducts opposed to one another must be avoided. A distance of 20 cm between these two different types of cables should not be exceeded.
- ➔ The power lines for the devices and the relevant data lines must be basically routed via the same cable route. Separating webs should be provided. In the horizontal area, it is advisable to keep a distance of max. 10 cm between these lines.
- ➔ If a lightning protection system is installed on the building, the safety distances between the power/data lines and elements of the external lightning protection system (air-termination systems, down conductors) must be kept and power / data lines must not be routed in parallel with

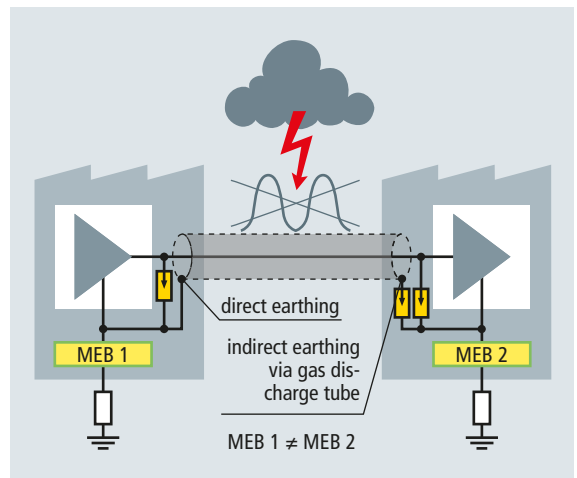

Figure 9.11.1 Shield connection on both ends – Shielding from capacitive/ inductive coupling and direct and indirect shield earthing to prevent equalising currents

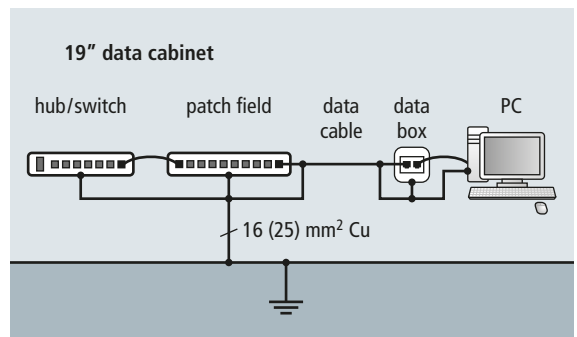

Figure 9.11.2 Equipotential bonding of a shielded cable system

the down conductors of the external lightning protection system.

- ➔ Use of optical fibre cables for the information technology cables of different buildings (campus backbone cabling)
- ➔ Installation of surge protective devices in power circuits and for the horizontal cabling system to protect them from transients caused by switching operations and lightning discharges (**Figures 9.11.3 and 9.11.4**)
- ➔ Power installation in the form of a TN-S system to prevent interference currents on the shields of the data lines
- ➔ Establishing main equipotential bonding with the power installation (PEN) at one point in the building (e.g. service entrance room)

To ensure proper EMC protection, it is also important to choose adequate lightning current and surge arresters for information technology systems and to be familiar with their protective effect.

Protective effect of arresters for information technology systems

For testing the electromagnetic compatibility (EMC), electrical and electronic equipment (devices) must have a defined immunity to conducted interference (surges).

Different electromagnetic environmental conditions require that the devices have different immunity levels. The immunity level of a device depends on the test level. To define the different immunity levels of terminal devices, the test levels are subdivided into four different levels from 1 to 4. Test level 1 places the lowest requirement on the immunity of a terminal device. The test level can be usually found in the documentation of the device or can be requested from the manufacturer of the device.



Figure 9.11.3 NET Protector – Universal surge protective device for protecting the data lines of a floor distributor (also suited for class D networks)

Arresters for information technology systems must limit conducted interference to an acceptable level so that the immunity level of the terminal device is not exceeded. For example, an arrester with a lower let-through value than the EMC test values of the terminal device must be selected for a terminal device tested with test level 2: Impulse voltage < 1 kV in combination with an impulse current of some amperes (depending on the type of injection).

Depending on the application and design, the information technology interfaces of terminal devices have different immunity levels. When selecting an adequate surge arrester, not only the system parameters are important, but also the fact whether the arrester is capable of protecting the terminal device. To ensure easy selection, an SPD class sign was developed for the Yellow/Line product family. Together with the documentation of the terminal device, this sign provides exact information on whether an arrester is suitable for the relevant terminal device, namely whether they are energy-coordinated with each other.

Correctly dimensioned surge arresters reliably protect terminal devices from voltage and energy peaks, thus increasing the availability of the installation.

Modern communication networks are increasingly becoming high-frequency networks and thus more and more susceptible to interference. Therefore, a consistent EMC concept that also includes lightning and surge protection for the buildings and systems is required to ensure smooth network operation (**Figure 9.11.5**).

Selection of surge protective devices

To ensure effective surge protection, the electricians and IT experts must coordinate the measures for the different systems in cooperation with the manufacturer of the device.



Figure 9.11.4 DEHNprotector – Universal surge protective device for protecting the network and data lines of a work station

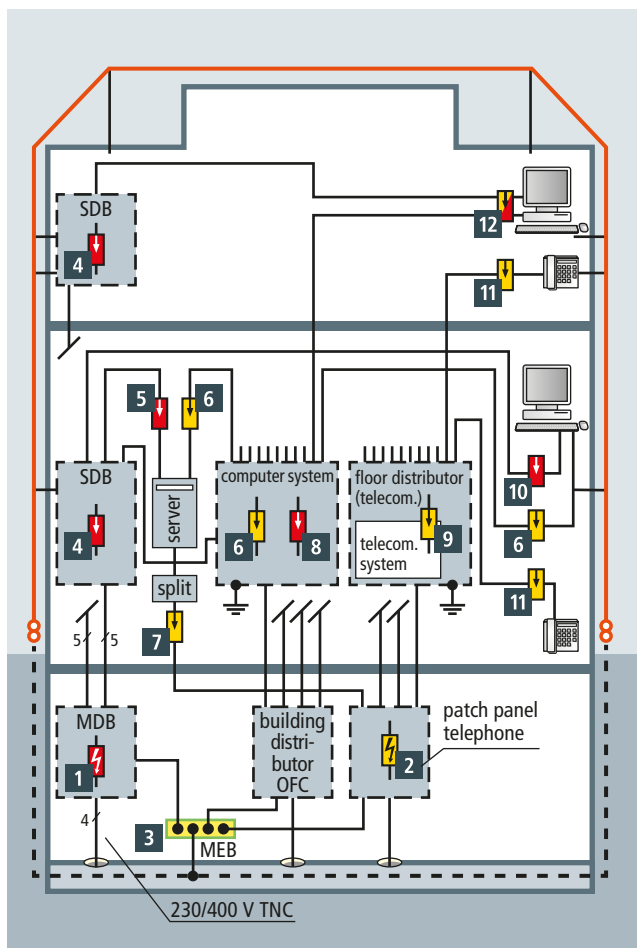

	SPD	Type	Part No.
1	DEHNventil	DV M TNC 255	951 300
2	Equipotential bonding enclosure	DPG LSA ... P	906 10...
	Disconnection block	TL2 10DA LSA	907 996
	DEHNrapid LSA	DRL 10 B 180 FSD	907 401
	Earthing frame	EF 10 DRL	907 498
	DEHNrapid LSA	DRL PD 180	907 430
3	Equipotential bonding bar	K12	563 200
4	DEHNguard modular	DG M TNS 275	952 400
5	DEHNrail modular	DR M 2P 255	953 200
6	DEHNpatch	DPA M CAT6 RJ45H 48	929 110
7	DEHNlink (upstream of splitter)	DLI TC 2 I	929 028
8	SFL Protector	SFL PRO 6X 19"	909 251
	NET Protector for 8 x 2 pairs	NET PRO TC 2 LSA	929 072
	19" enclosure	EG NET PRO 19"	929 034
10	DEHNflex M	DFL M 255	924 396
11	DSM telephone protection module	DSM TC 2 SK	924 272
12	DEHNprotector	DPRO 230 LAN100	909 321

Figure 9.11.5 Administration building with highly available installation parts

Therefore, experts (e.g. engineering consultants) must be called in for large projects.

